

To continue its program of quality and design improvement, the manufacturer reserves the right to change specifications, designs or prices without notice and without incurring obligation.

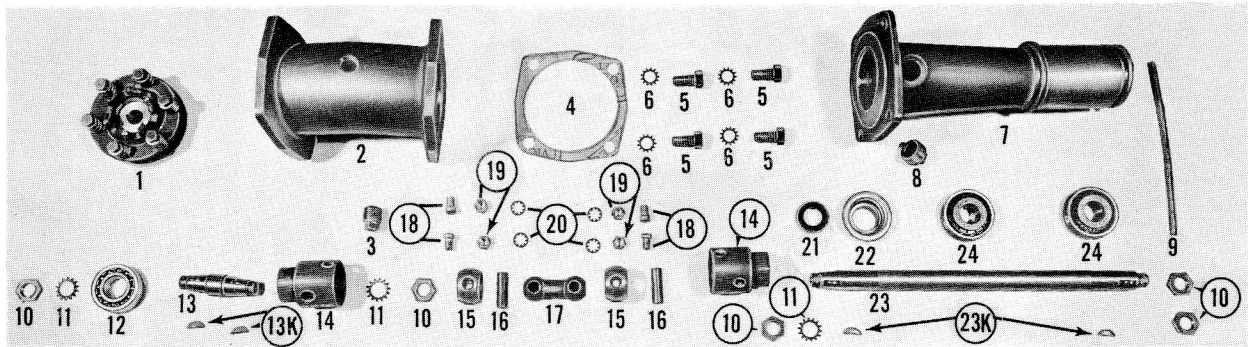

**PLATE SM 1**

Item No.	Part No.	Description
1		Slip Clutch Complete
2	3197	Universal Housing
3	702-P	Universal Housing Plug
4	5056	Universal Housing Gasket
5	160-S	Universal Housing Conn. Bolt
6	308-W	Universal Housing Conn. Link Washer
7	3107	Drive Column
8	703-VP	Drive Column Plug
9	3173	Swivel Cork Seal
10	1304	Crank Shaft and Stud Shaft Nut
11	309-W	Stud Shaft Lock Washer (Also Crank Shaft Link Washer)
12	3197-G	Stud Shaft Bearing
13	3197-F	Stud Shaft
13-K	504-K	Stud Shaft Key
14	3197-A	Universal Cup
15	3197-B	Center Ring
16	3197-D	Pivot Pin
17	3197-C	Link
18	3197-E	Pivot Stud
19	231-N	Pivot Elastic Stop Nut
21	L-126	Oil Seal Single
22	3151	Oil Seal Retainer
23	3142-A	Crank Shaft
23-K	504-K	Crank Disc Key
24	3147	Crank Shaft Bearing Assembly (Cone & Race)
	3147-C	Cone Only
	3147-R	Race Only

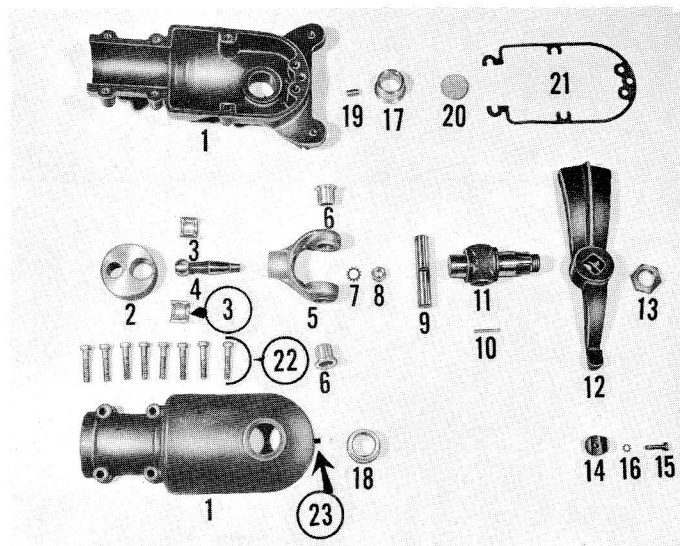

## PLATE SM 2

Item No.	Part No.	Description
1	3114 & 3115	Crank Housing Assembly
2	3143-A	Crank Disc
3	3145	Ball Stud Bearing
4	3144	Crank Yoke Ball Stud
5	3116	Crank Yoke
6	3178	Knuckle Pin Bearing
7	308-W	Ball Stud Washer
8	208-N	Ball Stud Nut
9	3176	Crank Yoke Knuckle Pin
10	3177	Knuckle Pin Lock Rivet
11	3179-S	Actuating Lever Shaft
12	3117-S	Knife Actuating Lever
13	225-N	Actuating Lever Nut
14	3182	Actuating Lever Wearing Tip
15	3154	Wearing Tip Bolt
16	303-W	Wearing Tip Lock Washer
17	3180-B	Lever Shaft Bearing (Slotted)
18	3180-T	Lever Shaft Bearing Top
19	3184	Crank Housing Dowell
20	3198	Crank Housing Expansion Plug
21	3191	Crank Housing Gasket
22	124-S	Crank Housing Bolt
NS	305-W	Crank Housing Bolt Lock Washer
23	701-P	Crank Housing Plug

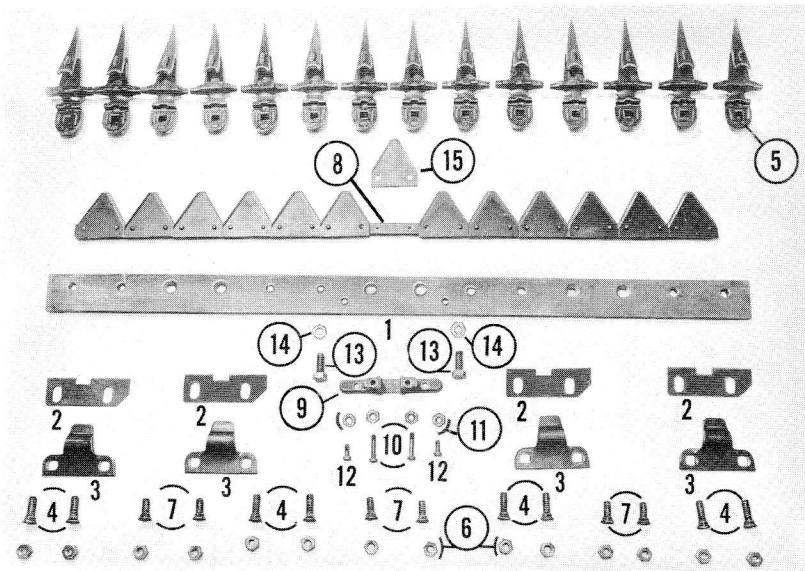

# PLATE SM 3

Item No.	Part No.	Description
1	3301	Guard Bar
2	3311	Wearing Plate
3	3309	Knife Clip
4	3304	Guard Bolt, Through Clip, Long
5	3302	Guard
6	3312	Guard Bolt Nut
7	3303	Guard Bolt, Short
8	3305	Knife Back
9	3308	Knife Drive Bracket 3"
10	M-531	Knife Drive Bracket, Bolt, Long
11	240-N	Knife Drive Bracket, Lock Nut
12	M-532	Knife Drive Bracket, Bolt, Short
13	152-S	Guard Bar Securing Bolt
14	211-N	Guard Bar Securing Bolt Nut
15	3206	Knife Section, .11 each,(Box of 25)
15	3206-F	Right Hand Bracket Section Each
15	3206-E	Center Bracket Section Each
15	3206-D	Left Hand Bracket Section Each
NS	3213	Skid Spacer
8-15	3306	Knife Back with Sections
NS	3307	Knife Rivets .02 each, per Pound
NS	3211	Skid w/Bolt
NS	3312	Skid Bolt Nut
	3211-AY	Skid Complete
	3302-A	Ledger Plate for Guards .20 each ( Box of 25)
	3302-B	Ledger Plate Rivets.03 Each (Per Pound)

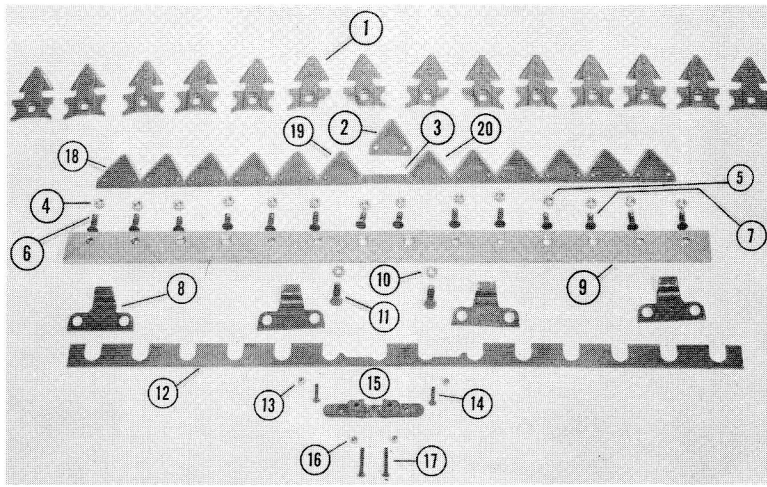

# PLATE SM 4

Item No.	Part No.	Description
1	3317	Guard
2	3206-E	Center Knife Section
3	3306	Knife 42"
	3306-4	Knife 48"
	3306-5	Knife 60"
4	3312	Hex Nut
5	3312	Hex Nut
6	3304	Bolt
7	3315	Bolt
8	3309	Knife Clip
9	3301	Guard Bar 42"
	3301-4	Guard Bar 48"
	3301-5	Guard Bar 60"
10	211-N	Nut
11	152-S	Bolt
12	3314	Wearing Strip 42"
	3314-4	Wearing Strip 48"
	3314-5	Wearing Strip 60"
13	240-N	Nut
14	M-532	Hex Head Cap Screw
15	3308	Knife Drive Bracket
16	240-N	Nut
17	M-531	Hex Head Cap Screw
18	3206	Regular Knife Section
19	3206-D	L.H. Knife Section
20	3206-F	R.H. Knife Section
NS	3307	Rivet
NS	3312	Skid Spacer
NS	3211-A	Skid